



ACORN SAFETY
P.O. BOX 3527
CITY OF INDUSTRY, CA 91744-0527
UNITED STATES OF AMERICA
WWW.ACORNSAFETY.COM

INSTALLATION, OPERATION AND MAINTENANCE INSTRUCTIONS

PEDESTAL MOUNTED ALL STAINLESS SHOWER



Models S2300-AS

TECHNICAL ASSISTANCE TOLL FREE TELEPHONE NUMBER
1.800.591.9360
TECHNICAL ASSISTANCE FAX: 1.626.855.4894

NOTES TO THE INSTALLER:

- 1. Please leave this documentation with the owner of the fixture when finished.**
- 2. Please read this entire booklet before beginning the installation.**
- 3. Check your installation for compliance with plumbing, electrical, ANSI Z358.1 and other applicable codes.**

LIMITED WARRANTY

UNITED STATES AND CANADA

Acorn Safety warrants that its products are free from defects in material or workmanship under normal use and service for a period of one year from date of shipment or 18 months after the date of shipment from factory, whichever comes first. Acorn's liability under this warranty shall be discharged solely by replacement or repair of defective material, provided Acorn is notified in writing within one year from date of shipment, F.O.B. Industry, California.

This warranty does not cover installation or labor charges and does not apply to materials, which have been damaged by other causes such as mishandling or improper care or abnormal use. The repair or replacement of the defective materials shall constitute the sole remedy of the Buyer and the sole remedy of Acorn under this warranty. Acorn shall not be liable under any circumstances for incidental, consequential or direct charges caused by defects in materials, or any delay in the repair or replacement thereof. This warranty is in lieu of all other warranties expressed or implied. Product maintenance instructions are issued with each unit and disregard or non-compliance with these instructions will constitute an abnormal use condition and void the warranty. Stainless steel must be protected on job sites during construction and must be properly maintained after the water has been introduced into the safety product or Acorn's warranty is void.

PRELIMINARY STEPS

1. Read the installation instructions prior to beginning the installation.
2. Separate parts from packaging and verify all necessary parts are accounted for and undamaged. Obtain missing or damaged parts from Acorn Safety prior to beginning installation.
3. Flush water supply lines prior to installation. This will remove unwanted debris from the lines and prevent unwanted blockages in the safety equipment.
4. In order to comply with ANSI Z358.1, the safety equipment must be inspected periodically. An inspection tag is provided for documentation purposes.
5. All employees at risk of contamination should be informed and trained in the use of this and any other safety equipment. The signage provided should be posted appropriately in close proximity to this equipment.

ROUGH-IN

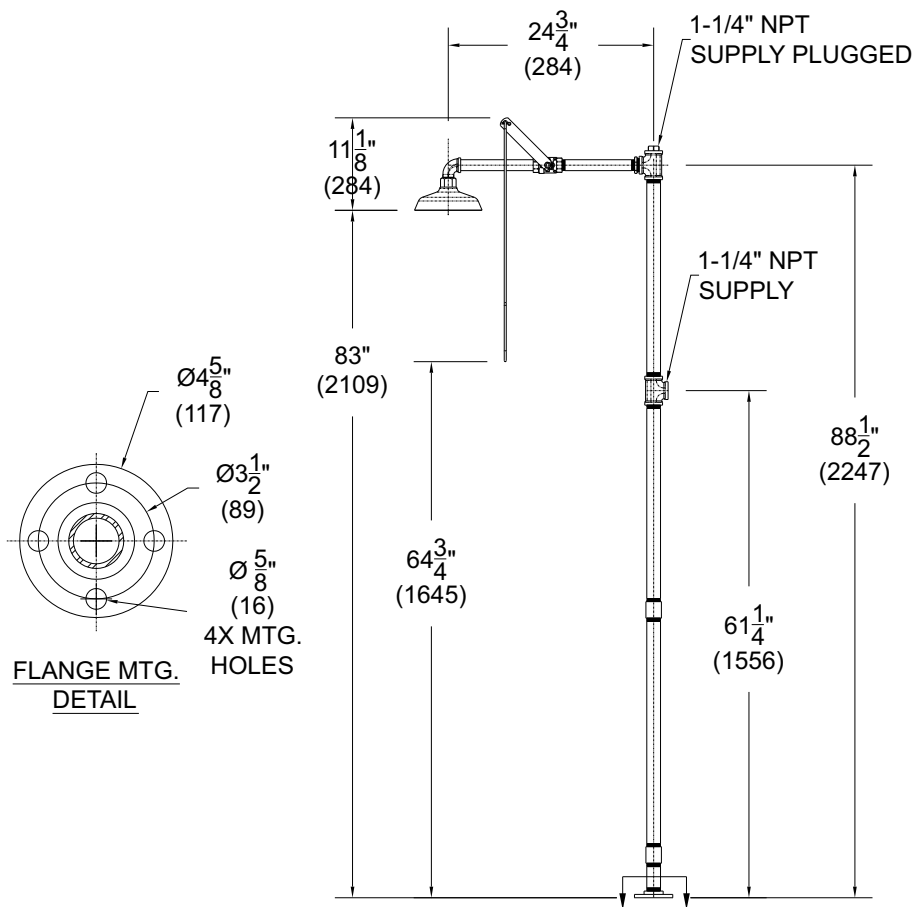

NOTES:

1. ALL DIMENSIONS ARE IN INCHES (MM)
2. ANSI Z358.1 REQUIRES THE SHOWER HEAD TO BE MOUNTED BETWEEN 82"(2083) AND 96" (2438) ABOVE THE FLOOR.

INSTALLATION INSTRUCTION

Supplies required: (not provided by Acorn)

1. Wall fasteners, washers, anchors and screws.
2. Pipe sealant or Teflon tape for sealing water connections.

IMPORTANT: FLUSH WATER SUPPLY LINES PRIOR TO CONNECTION TO SAFETY EQUIPMENT.

Notes:

- Bottom of shower head must be between 82"-96" from finished floor in order to meet ANSI Z358.1
- Use hand tools and wrenches in a manner which will prevent marring finished surfaces. Strap wrenches or tools with plastic jaw linings are highly recommended.
- Refer to Rough-in for location of supply and drain lines.
- Fragments of Teflon tape or pipe sealant residue can interfere with the proper operation of this unit. Ensure pipe sealant methods do not cause contamination in the system.
- Prior to beginning assembly, TURN OFF water supply to 1 1/4" potable water supply line.

STEP ONE: PEDESTAL

1. Position center of pedestal flange "R" a minimum of 0'-9" from left and rear wall. Position from center of flange a minimum of 0'-11" from right side wall.
2. While holding the flange in position, mark floor flange mounting hole positions.
3. Remove the flange and install appropriate floor anchors to receive mounting bolts (supplied by others).
4. Re-position the flange and install mounting bolts and washers.

STEP TWO: UPPER SHOWER ASSEMBLY

1. Assemble components "B, C, D, E, F, L, M, N, P & R" in sequential order using proper plumbing techniques to seal all made up threads.
*NOTE PROPER ORIENTATION OF COMPONENT "C" SHOWN IN DETAIL VIEW
2. Ensure that fittings are aligned and perpendicular as shown to allow for later stages of assembly
3. Assemble components "G & H" in a similar manner.
4. Assemble component "I" to valve.

Step three: SUPPLY AND SANITARY DRAIN CONNECTION

Note: Refer to Rough-In for supply line locations.

1. Install necessary pipe fittings (supplied by others) to make connection to 1 1/4" NPT supply tee w/ potable water supply line.

STEP FOUR: TEST

1. Verify 1" supply valve for shower are turned OFF.
2. Turn on water supply to 1 1/4" potable water supply.
3. Inspect system for leaks.
4. Verify shower wash flows properly.

STEP FIVE: SIGNAGE AND INSPECTION

1. Install sign "J" with clear visibility as shown, with appropriate hardware (supplied by others).
2. Attach inspection tag "K" supplied, with plastic zip tie to 1 1/4" supply line as shown.

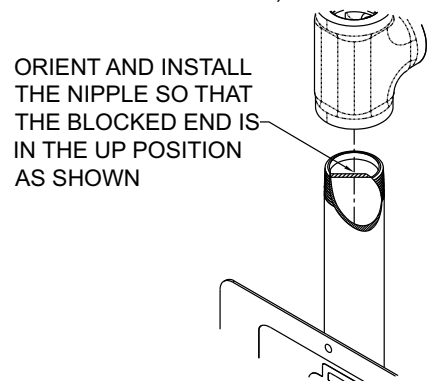
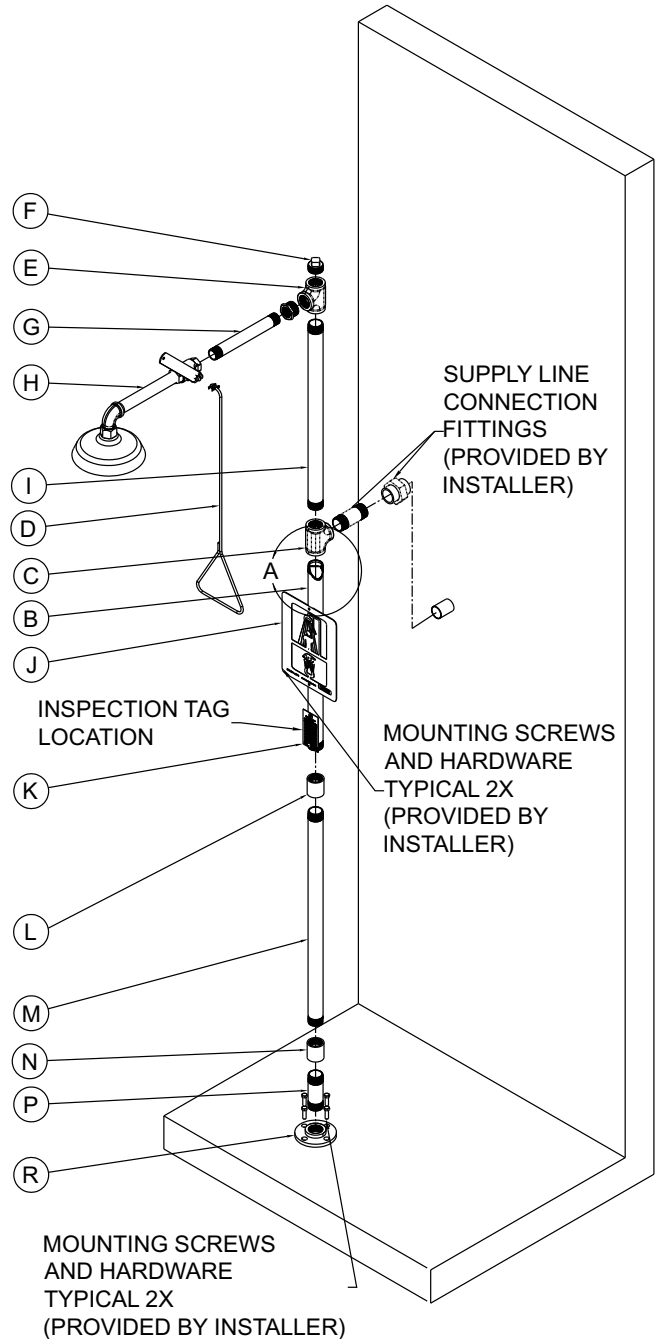

DETAIL A
SCALE 1 : 4

OPERATION INSTRUCTIONS:

Employees who work with hazardous materials should become familiar with the location and operation of the nearest emergency plumbing fixture. In addition, proper clothing and equipment should be worn whenever working with hazardous materials. Emergency plumbing fixture stations are simple to use and require hands free operation once the station is activated. Regular instruction regarding proper care and use will increase confidence that the units are accessible and function properly.

The route and area surrounding the Drench Shower should be clear and unobstructed; the sooner a person has rinsed off any contamination, the less likelihood of injury. Drench Shower stations should be located in close proximity to the hazard and take no more than 10 seconds to reach. In the possibility of a strong acid or strong caustic contamination the Drench Shower should be immediately adjacent to the hazard. The victim may require assistance to the Drench Shower station and help removing shoes and clothing.

1. To start the Drench Shower pull down on the pull handle to "ON" position. The Drench Shower will start.
2. Stand directly under the spray pattern. Clothing should be removed immediately prior to or during the rinsing to prevent contamination from remaining against the body causing unnecessary injury and pain. Accept assistance removing shoes and clothing.
3. Completely rinse with arms and legs separated for approximately 15 minutes or until medical personnel arrive. Be prepared to inform medics on the type of substance that is causing the injury or contamination.
4. When finished push up on the pull handle to "OFF" position. Drenching fluid should stop.

MAINTENANCE GUIDE:

Maintain and inspect in accordance with ANSI Z358.1-2009

1. Check for obvious signs of wear, broken or defective equipment. Re-paint if necessary. Replace missing or defective equipment such as broken push paddles, missing signs and inspection tags.
2. Operate Drench Shower using the pull handle to place ball valve in the fully "ON" position checking for smooth operation of valve push paddle mechanism. If the ball valve does not operate smoothly check the actuating assembly for binding or missing parts.
3. Return push handle to vertical or fully "OFF" position.

PARTS LIST

ITEM #	PART NUMBER	DESCRIPTION
1	7100-129-000	1-1/4" NPT STN. STL. PLUG
2	7100-131-000	TEE 1-1/4" X 1-1/4" X 1-1/4" STN.STL.NPT
3	7100-215-000	REDUCER, 1" FEMALE NPT X 1 1/4" MALE NPT, S/S
4	2015-010-000	1"-11.5"X10" NPT STN. STL. NIPPLE
5	7102-414-002	ASSY, BALL VALVE, HORIZ. S/S, 1" THRD.
6	7102-414-001	STN.STL. PIPE ASSY, HORIZ. SHOWER
7	7102-351-000	REGULATOR, FLOW RATED 23.76 GPM
8	7100-197-199	1-1/4" PIPE NIPPLE STN. STL. 24.875" L
9	7102-305-001	STAINLESS STEEL SHOWER HEAD ASSY -NO LIP
10	7100-131-000	TEE 1-1/4" X 1-1/4" X 1-1/4" STN.STL.NPT
11	7102-350-000	PULL HANDLE, DRENCH SHOWER, 29"
	7102-345-000	PULL HANDLE, DRENCH SHOWER, 59.50"
12	7100-401-000	EYE / SHOWER SERVICE TAG
13	7101-415-001	NIPPLE SUBASSY BLOCKED END S/S
14	7101-017-000	1-1/4" PIPE COUPLING STN. STL.
15	7100-211-000	.072 DIA. COTTER PIN,BOWTIE STN.STEEL
16	7100-219-000	WASHER, NYLON, .15 THK X .50 OD X .25 ID
17	7100-204-199	1-1/4" PIPE NIPPLE STN. STL. 28.75" L
18	7101-017-000	1-1/4" PIPE COUPLING STN. STL.
19	7100-185-000	1 1/4 x 4 1/2"L NPT S/S PIPE
20	7100-137-000	1 1/4" NPT S/S FLOOR FLANGE

